

Alpha[®] 5" Pneumatic Angle Grinder Instruction Manual

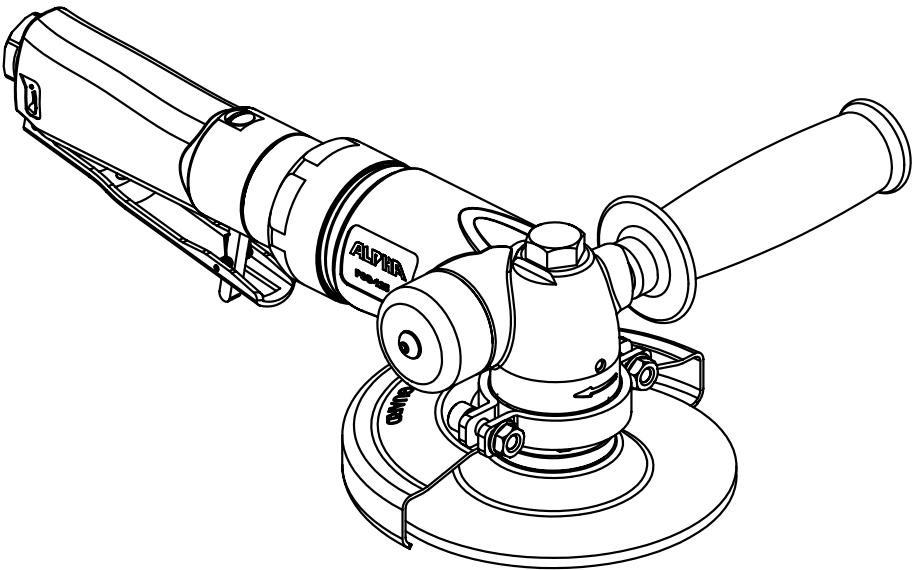

Part No: PSG-125
Version 1

 **Alpha Professional Tools**[®]

103 Bauer Drive, Oakland, NJ 07436 • 800-648-7229 • Fax: 800-286-0114
www.alpha-tools.com

TABLE OF CONTENTS

Introduction.....	3
About the Symbols	3
Safety Instructions for Pneumatic Tools	4
PSG-125 Overview.....	6
Specifications.....	6
Equipment Included.....	7
Additional Precautions for Using the Pneumatic Angle Grinder	8
Air Pressure and Volume.....	9
Rust Protection.....	9
Cleaning the Rotor Assembly.....	9
How to Add the Rust Inhibitor Oil	10
Filter/Regulator System.....	11
Connecting the Air Supply	11
Spindle Size.....	12
Sound Level.....	12
Attaching the Safety Guard	12
Mounting Diamond Wheels	13
Attaching the Side Handle	13
Operation.....	14
Throttle Operation	14
Exhaust Vent	14
PSG-125 Pneumatic Angle Grinder Schematic.....	15
PSG-125 Pneumatic Angle Grinder Parts List.....	16
Accessories and Factory Service	18
Product Registration	19

INTRODUCTION

Thank you for purchasing an Alpha® PSG-125 Pneumatic Angle Grinder. Please read this instruction manual thoroughly to ensure safe and correct use of the Pneumatic Angle Grinder. Keep this manual in a place where operators can access it easily whenever necessary.

► ABOUT THE SYMBOLS

According to the hazard level, all safety notes in this manual are classified into “DANGER”, “WARNING”, and “CAUTION”.

 **DANGER!** Death or serious personal injury is imminent when handling this pneumatic angle grinder incorrectly.

 **WARNING!** There is a possibility of death or serious personal injury when handling this pneumatic angle grinder incorrectly.

 **CAUTION!** There is a possibility of personal injury or property damage when handling this pneumatic angle grinder incorrectly.

Note: In some situations, failing to observe WARNING notes could result in death or serious personal injury. Be sure to read and observe the safety notes to ensure safety and correct use of the pneumatic angle grinder.

► SAFETY INSTRUCTIONS FOR POWER TOOLS

1. **KNOW YOUR POWER TOOL.** Read owner's manual carefully. Learn its applications and limitations as well as specific potential hazards particular to this tool.
2. **KEEP WORK AREA CLEAN.** Cluttered areas and benches invite accidents.
3. **AVOID DANGEROUS ENVIRONMENTS.** Keep work areas as dry as possible. Do not use tool in presence of flammable liquids or gases. Keep the area well lit.
4. **KEEP CHILDREN AND VISITORS AWAY.** All visitors should be kept a safe distance from the work area. Keep out of reach of children.
5. **DON'T FORCE TOOL.** It will do the job better and safer at the rate for which it was designed.
6. **WEAR PROPER APPAREL.** Do not wear loose clothing or jewelry as it can get caught in moving parts. Rubber gloves and insulated non-skid footwear are recommended. Wear protective covering to contain long hair.
7. **WEAR PROPER EYE PROTECTION.** All users and bystanders must always wear proper personal eye protection which conform with ANSI/ISEA Z87.1 (CAN/CSA Z94.3). Also use a face or dust mask if operation is dusty. Always wear certified safety equipment.
8. **WEAR PROPER EAR PROTECTION.** All users and bystanders must wear proper personal ear protection which conforms with ANSI S12.6 (S3.19) hearing protection.
9. **WEAR PROPER RESPIRATORY PROTECTION.** All users and bystanders must wear proper personal respiratory protection. Always use NIOSH/OSHA approved respiratory protection appropriate for the dust exposure.

Warning: Some dust created by power sanding, sawing, grinding, drilling, polishing and other construction activities contains chemicals known to the State of California to cause cancer, birth defects, or other reproductive harm.

Some examples of these chemicals are:

- Lead from lead-based paints
- Crystalline silica from bricks, cement and other masonry products, and
- Arsenic and chromium from chemically-treated lumber.

Your risk from these exposures varies, depending on how often you do this type of work. To reduce your exposure, work in a well ventilated area, and work with approved safety equipment, such as dust masks that are specially designed to filter out microscopic particles.

To familiarize with the risks associated with a material, consult with your employer, manufacturer/supplier and government agencies regarding the hazards of the materials and their recommendations to protect yourself.

- 10. DON'T ABUSE AIR SUPPLY HOSE.** Don't carry tool by supply hose or expose to traffic areas where it can be crushed.
- 11. ALWAYS SECURE WORK PIECE.** Use clamps or a vise to hold work. It's safer than using your hand and it frees both hands to operate tool.
- 12. DON'T OVERREACH.** Keep proper footing and balance at all times.
- 13. DISCONNECT TOOLS WHEN NOT IN USE.** Always disconnect tool before servicing when changing blades.
- 14. REMOVE ADJUSTING KEYS AND WRENCHES.** Form a habit of checking to see that keys and adjusting wrenches are removed from tool before turning it on.
- 15. MAINTAIN TOOLS WITH CARE.** Keep tools clean at all times for best and safest performance. Follow instructions for lubricating and changing accessories. Keep handles dry, clean and free of oil or grease. Inspect moving parts for alignment and binding as well as for breakage and improper mounting.
- 16. AVOID ACCIDENTAL STARTING.** Do not carry a "connected" tool, or make adjustments, or change discs without making sure the tool is disconnected from the air supply.
- 17. USE ONLY RECOMMENDED ACCESSORIES.** The use of any accessories other than what is listed or recommended for this particular tool may be hazardous.
- 18. KEEP HANDS AWAY FROM ALL MOVING PARTS.**
- 19. USE SIDE HANDLES.** Supplied with tool for control and safety.
- 20. STAY ALERT.** Watch what you are doing and use common sense. Do not operate tool when you are tired, or under the influence of medication or alcohol.

5" PNEUMATIC ANGLE GRINDER OVERVIEW

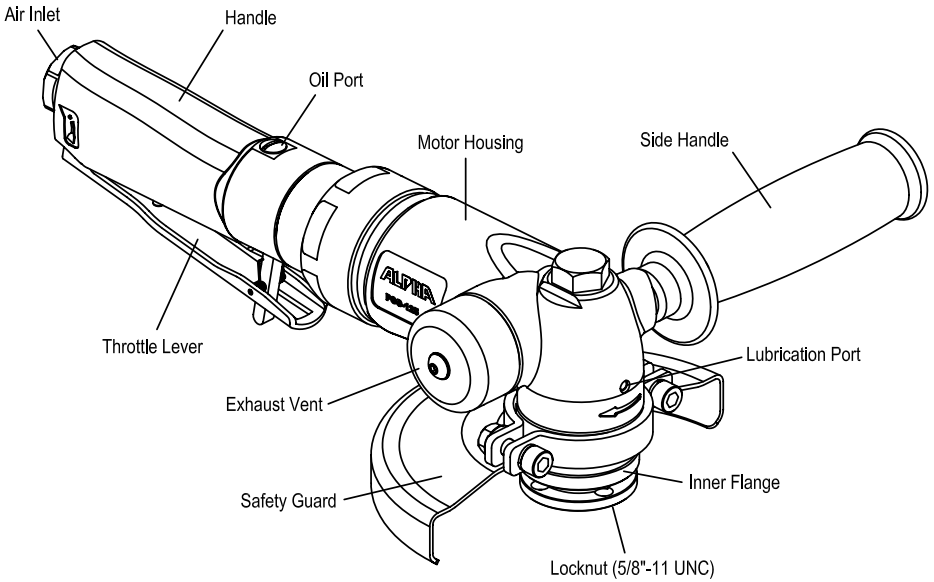

Figure 1

► SPECIFICATIONS:

Air Pressure	90 PSI
Air Consumption Max.	33 CFM / 934 L/Min
No Load RPM	12,000
Weight.....	4.6 lbs (2.1 kg)
Length.....	11-3/4" (298mm)
Air Inlet.....	3/8" NPT
Spindle.....	5/8"-11
Max. Disc Capacity	5" x 1/4" x 7/8"
Max HP	1.4 HP

EQUIPMENT INCLUDED

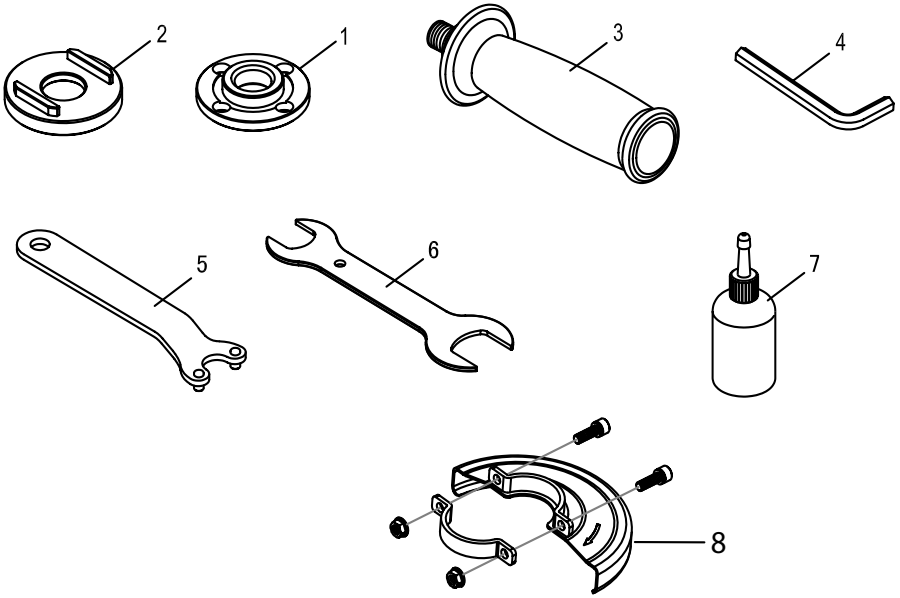

Figure 2

- | | |
|--|------|
| 1. Lock Nut with 7/8" Arbor..... | 1 pc |
| 2. Inner Flange..... | 1 pc |
| 3. Side Handle | 1 pc |
| 4. Hex. Wrench (1/4")..... | 1 pc |
| 5. Pin Wrench..... | 1 pc |
| 6. Double Open-End Wrench (1" / 32mm) | 1 pc |
| 7. Rust Inhibitor Oil (8oz / 237ml) (AIR-008)..... | 1 pc |
| 8. Safety Guard..... | 1 pc |

ADDITIONAL PRECAUTIONS FOR USING THE PNEUMATIC ANGLE GRINDER

In addition to the general safety notes described on the preceding pages, please read and observe the following precautionary notes before using the pneumatic grinder .

 **DANGER!**

► INSTRUCTIONS

Alpha Professional Tools® provides the highest quality parts and manufacturing techniques in the manufacture of this tool. In order to obtain the maximum effectiveness and provide the highest degree of safety, it is necessary to review and follow these instructions carefully before using the tool.

► SAFETY ADVICE

- Please note safety instructions on Page 4-5.
- Always disconnect the air line before making any changes to the settings or carrying out maintenance.
- Keep water and air lines clear from working range of the machine. These lines should always lead away from you and behind the operating area.
- Before use, check the machine, hose and fittings for any damage or material fatigue, only authorized service agents should carry out repairs.
- Always wear safety glasses and respiratory protection when working with this machine. It is further recommended to wear safety gloves, apron, as well as sturdy non-slipping shoes.
- Only use saw blades whose permitted speed is at least as high as the highest no-load speed of the machine.
- Be sure saw blade fits the tool properly and securely. Do not modify the tool to force fit the blade. For example, do not remove blade guard.
- Check blades before use. The saw blade must be properly mounted and turn freely. Perform a test run for at least 30 seconds without any load. Do not use damaged, out of round or vibrating blades.
- Immediately switch off the machine in case of considerable vibrations or if other malfunctions occur. Check the machine in order to find out the cause.
- Always use and store the saw blades according to the manufacturer's instructions. The flange bolt must be tightened before starting to work with the machine.
- The work piece must be secured if it is not heavy enough to prevent movement.
- The tool is designed for cutting on horizontal surfaces.

► AIR PRESSURE AND VOLUME

The recommended air pressure for this pneumatic angle grinder is 90 PSI. The most important factor in running this angle grinder is the volume of air being supplied to the angle grinder. The volume is the air consumption needed to run this angle grinder at a constant speed under light downward hand pressure. The volume is measured in CFM (cubic foot per minute (ft³/min)). Alpha® recommends running the tool at the maximum flow volume of 33 CFM to get the full 1.4 HP rating out of the angle grinder.

It is also very important to keep your air cool, dry, and clean, so look for a compressor with a refrigerated dryer and high-efficiency filter built-in or purchase a separate air dryer and filter unit rated for your compressor's CFM. **(See page 11 for Alpha® Filter/Regulator Manifold System)**

► RUST PROTECTION (A rust inhibitor oil is used to protect the tool from rusting when not in use)

PROPER CARE AND MAINTENANCE ARE IMPORTANT FACTORS IN PREVENTING THIS TOOL FROM RUSTING ON THE INSIDE WHEN NOT IN USE.

At the end of each workday, place 4-5 drops of rust inhibitor oil (included with each angle grinder) into the tool using the oil port. Depress the throttle lever varying the speed from very low to half speed, for thirty seconds. This will allow the oil to transition into the rotor assembly and coat the inside of the tool.

► CLEANING THE ROTOR ASSEMBLY

Over time, the rotor assembly can fill up with oil sludge, vane dust residue, and contamination and will need to be cleaned. To accomplish this, remove the muffler assembly from the tool to allow the waste to exit. You can hold a paper towel over the exit port to reduce the sound level and catch the exiting waste. Add 10 to 20 drops of oil to the oil port and run the tool varying the speed from very slow to half speed, for two to three minutes to allow the oil to process through the machine. Check the paper towel for exit waste, continue until there is little to no exit waste.

Run the tool at its slowest speed. If the tool sounds like it is running with a variation in speed, this is an indication that one of the vanes is still sticking in the rotor. Repeat the process to see if this will correct the variation in sound. If the problem continues, contact an authorized Alpha® Repair Center for routine repair and maintenance.

► HOW TO ADD THE RUST INHIBITOR OIL

1. Disconnect the angle grinder from your air supply.

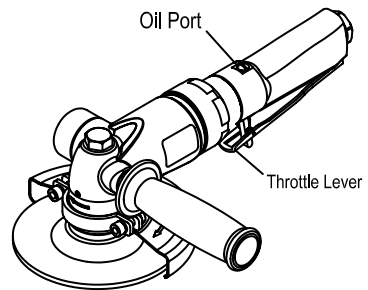

2. Remove the screw using a screw driver. (See Fig. 3)

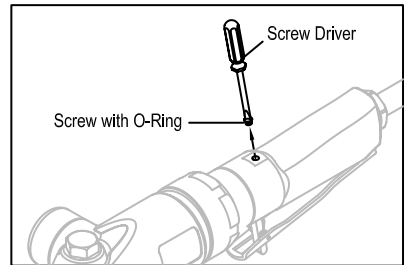

Figure 3

3. Add 4-5 drops of the Rust Inhibitor Oil into the oil port. (See Fig. 4)
4. Reinstall the Oil screw.

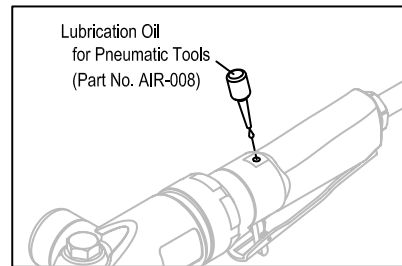

Figure 4

5. Reconnect the pneumatic angle grinder to your air supply.
6. Depress the throttle lever varying the speed from very low to half speed, for thirty seconds. (See Fig. 5)

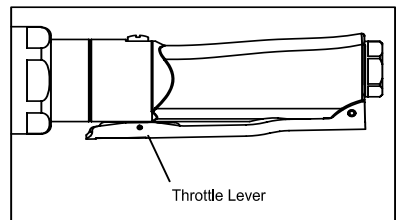

Figure 5

Replacement Rust Inhibitor Oil can be purchased from Alpha® Professional Tools (Part No. AIR-008).

CAUTION!

Lubricating the pneumatic grinder before and during work is not needed. Excessive oil will turn to a tar-like substance inside the tool, causing the vanes to stick in the rotor and slow the tool down. This is the reason we do not recommend automatic oilers to be used with this angle grinder. Old or worn compressors, which emit oil through the air lines, can significantly shorten the life of the tool.

HELPFUL HINT:

- Air throttle lever should be pressed and released slowly to allow the angle grinder to accelerate and decelerate during all applications. Rapid acceleration and deceleration can wear out the ball bearings prematurely.

HELPFUL HINT:

- Using a Filter Regulator System is Recommended

► FILTER/REGULATOR SYSTEM

Having a Filter/Regulator (See Fig. 6) helps prevent pressure drops when using a large volume of air, so you can set the pressure of the pneumatic angle grinder to 90 PSI, while the main system can run at 125 PSI. The F/R unit will also remove any water from the air supply while also filtering the air of contamination down to five microns.

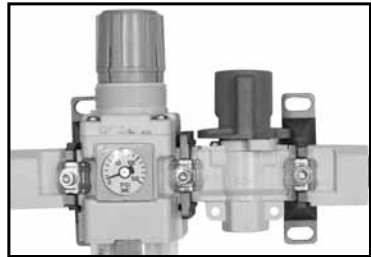

Figure 6

By only using aluminum and brass after the F/R unit, you are eliminating any rust and contamination from getting into the air tools.

Alpha® recommends the F/R Manifold 53 CFM for single use with the PSG-125 (Part No.1030-0022). All F/R manifolds are available through our distributor network, and via our website.

► CONNECTING THE AIR SUPPLY

The air Inlet for this pneumatic angle grinder is 3/8" NPT. Using a 3/8" or 1/2" inner diameter hose is highly recommended when operating this tool. ***An air supply hose is not included with the PSG-125 Pneumatic Angle Grinder.***

HELPFUL HINT:

Use Hi-Flo couplers and plugs to obtain the maximum CFM through the tool.

► SPINDLE SIZE

The Alpha® PSG-125 Pneumatic Angle Grinder has a 5/8"-11 spindle thread.

Maintenance and Usage Tip:

- Do not leave the angle grinder submersed in water. This could expose the inner moving parts to moisture, which will shorten the life of the angle grinder.
- Excessive force or impact to the spindle may result in premature failure of gears and/or bearings, which may not be immediately evident.

► SOUND LEVEL (HEARING PROTECTION MUST BE WORN)

To comply with OSHA Occupational Noise Exposure Standard Number 1926.52, this tool is equipped with an internal Silencer System. When the tool is operated correctly at 90 PSI, the sound level emitted should be less than 86.4 dBA. The internal Silencer System is also used to maintain a constant back pressure inside the tool; this helps prevent it from exceeding the recommended 12,000 RPM. The exhaust deflector for this angle grinder also helps to reduce the noise level by venting the exhaust air.

ATTACHING THE SAFETY GUARD

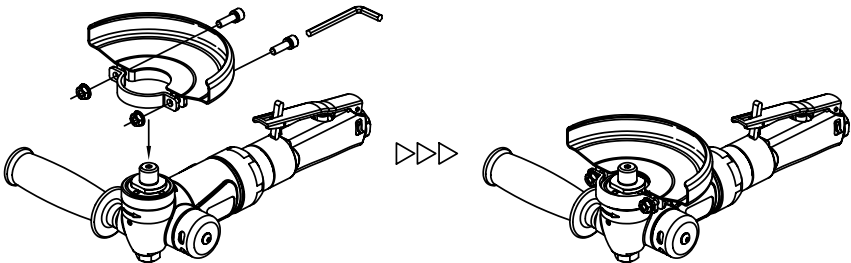

Figure 7

1. Attach the Safety Guard onto PSG-125
2. Tighten nuts and hex screws to secure the safety guard.

MOUNTING DIAMOND WHEELS

OPTION 1

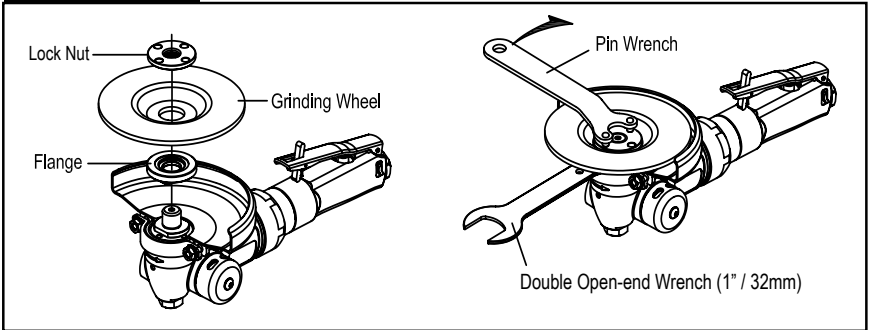

Figure 8

OPTION 2

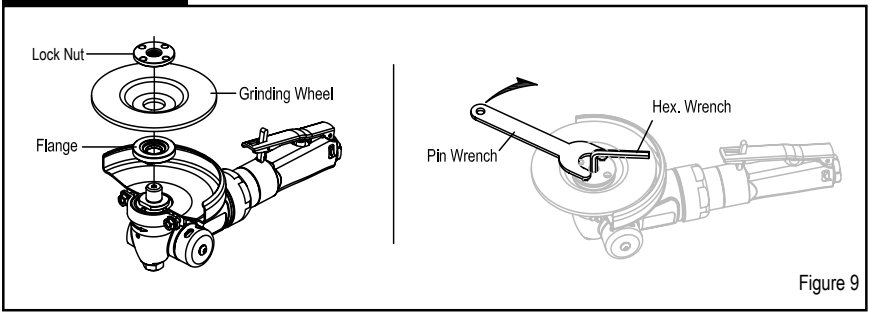

Figure 9

ATTACHING THE SIDE HANDLE

Attach the handle into one of the two appointed locations for the most comfort and stability when operating this tool. (See Fig. 10)

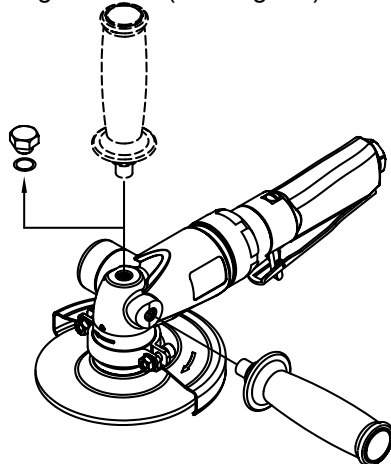

Figure 10

OPERATION

► THROTTLE OPERATION

Press the safety bar forward to unlock the spring mechanism. Grip the body in a way that the throttle lever is depressed to activate the motor. Releasing the throttle lever shuts down the motor.

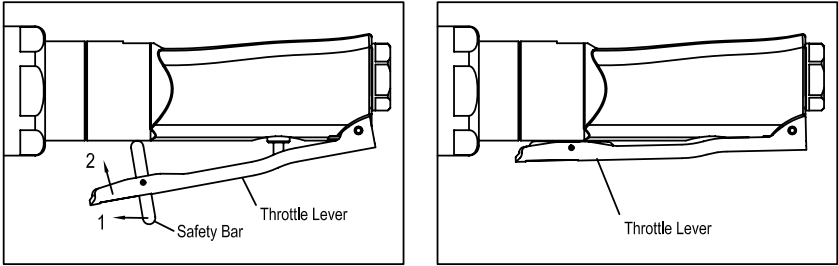
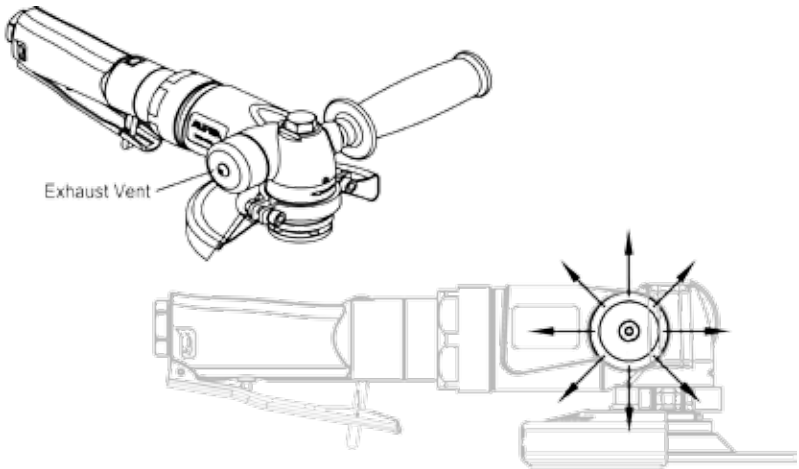

Figure 11

► EXHAUST VENT



The exhaust vent cover can be rotated 180 degrees to divert the air flow coming out of the Pneumatic Angle Grinder.

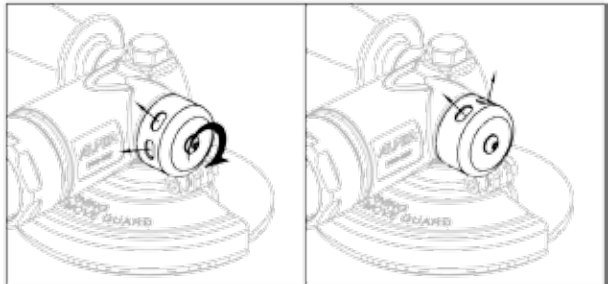
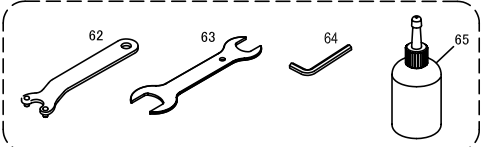
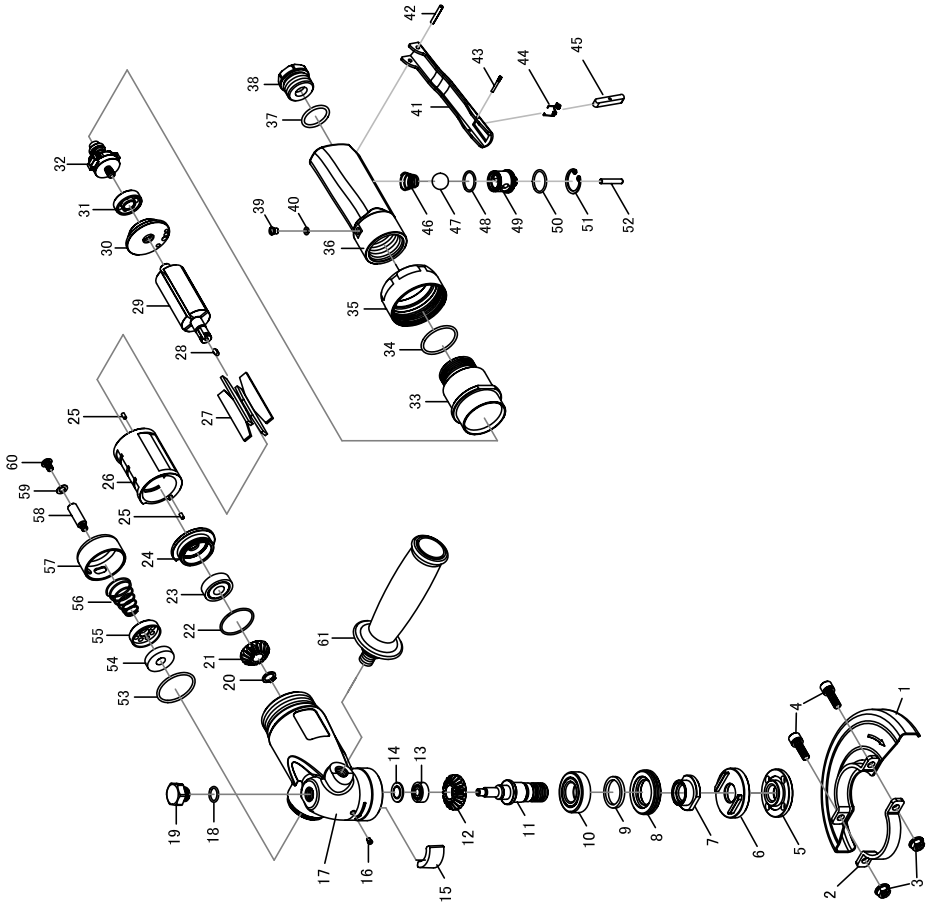

Figure 12

ALPHA® PSG-125 5" PNEUMATIC ANGLE GRINDER SCHEMATIC



ALPHA® PSG-125 5" PNEUMATIC ANGLE GRINDER PARTS LIST

DRAWING NO.	PART NO.	DESCRIPTION	QTY
1	3002-0001	5" Safety Guard	1
2	3002-0002	Retainer	1
3	3002-0003	Nut (M6)	2
4	3002-0004	Screw (M6x20)	2
5	3002-0005	Flange Nut (5/8"-11)	1
6	3002-0006	Flange	1
7	3002-0007	Spacer Nut	1
8	3002-0008	Lock Nut	1
9	3002-0009	Oil Felt	1
10	3002-0010	Ball Bearing (6003LLU)	1
11	3002-0011	Spindle (5/8"-11)	1
12	3002-0012	Bevel Gear	1
13	3002-0013	Ball Bearing (606ZZ)	1
14	3002-0014	Bearing Holder	1
15	3002-0015	Oil Felt	1
16	3002-0016	Lubricator	1
17	3002-0017	Housing	1
18	3002-0018	O-Ring (9.5x1.5)	1
19	3002-0019	Screw (M12x3T)	1
20	3002-0020	Retaining Ring (STW-9)	1
21	3002-0021	Bevel Pinion Gear	1
22	3002-0022	O-Ring (21.5x1.5)	1
23	3002-0023	Ball Bearing (6000LLU)	1
24	3002-0024	Front Bearing Case	1
25	3002-0025	Spring Pin (2.5x5)	2
26	3002-0026	Cylinder	1
27	3002-0027	Vane (4pc set)	1
28	3002-0028	Key (3x8L)	1
29	3002-0029	Rotor	1
30	3002-0030	Rear Bearing Case	1
31	3002-0031	Ball Bearing (609)	1
32	3002-0032	Governor Assembly	1
33	3002-0033	Inlet Guide	1
34	3002-0034	O-Ring (28.5x2)	1
35	3002-0035	Nut	1

ALPHA® PSG-125 5" PNEUMATIC ANGLE GRINDER PARTS LIST (CONT'D)

DRAWING NO.	PART NO.	DESCRIPTION	QTY
36	3002-0036	Rear Body	1
37	3002-0037	O-Ring (19.8x2.4)	1
38	3002-0038	Air Inlet	1
39	3002-0039	Screw	1
40	3002-0040	O-Ring (3.5x1.5)	1
41	3002-0041	Throttle Lever	1
42	3001-0072	Spring Pin (3x20L)	1
43	3002-0043	Pin	1
44	3001-0069	Spring	1
45	3001-0068	Safety Bar	1
46	3002-0046	Spring	1
47	3002-0047	Nylon Ball	1
48	3002-0048	O-Ring (13.5x1.5)	1
49	3002-0049	Bushing	1
50	3002-0050	O-Ring (15.5x1.5)	1
51	3002-0051	Retaining Ring (RTW-20)	1
52	3002-0052	Pin (4x22.8)	1
53	3002-0053	O-Ring (27x2)	1
54	3002-0054	Muffler	1
55	3002-0055	Exhaust Vent	1
56	3002-0056	Spring	1
57	3002-0057	Exhaust Cover	1
58	3002-0058	Spacer Screw	1
59	3002-0059	Washer (5.3x10x0.3)	1
60	3002-0060	Screw (M5x8L)	1
61	3001-0015	Side Handle Assembly	1
62	3002-0062	Pin Wrench (P:32mm)	1
63	3002-0063	Double Open End Wrench (1" / 32mm)	1
64	3002-0064	Hex. Wrench (1/4")	1
65	AIR-008	Rust Inhibitor Oil (8oz / 237ml)	1

For repair information call:

Headquarters, Oakland, NJ — (800) 648-7229 ext.505

Due to specially designed components this machine must be serviced only with genuine ALPHA® parts.

► ACCESSORIES AND FACTORY SERVICE

All the accessories can be purchased at a local distributor in your area. For more information concerning Alpha® Pneumatic Angle Grinder and factory service, please contact the Alpha® distribution centers listed below.

COMPANY HEADQUARTERS & REPAIR CENTER:

Alpha Professional Tools®
103 Bauer Drive
Oakland, NJ 07436

Hours of Operation:

8:30 a.m. – 5:00 p.m. EST

Telephone Number:

201-337-3343

Toll-Free Number:

800-648-7229

CANADIAN REPAIR CENTER:

Edgewood Sales & Marketing
10 Simon Court
Waterford, ON N0E 1Y0

Telephone Number:

519-896-4992

► WARRANTY

Limited Warranty of Alpha® Pneumatic Angle Grinder (PSG-125) for USA and Canada ONLY!

Alpha Professional Tools® warrants this product against defects in material and workmanship for a period of one year from the date of original retail purchase (proof of purchase required). If Alpha Professional Tools® receives notice of such defects during the warranty period, our obligation assumed under this warranty is limited to the repair or replacement of parts, without charge. This warranty does not apply to Alpha® accessories. Returns within the warranty period should be sent in freight prepaid to an Authorized Warranty Service Center.

The warranty does not apply in situations where:

- The tool has been misused, abused or improperly maintained
- Alterations or repairs were made by others
- Repairs due to normal wear and tear

Some States do not allow limitations on how long an implied warranty lasts or the exclusion or limitation of incidental or consequential damages, so the above limitation may not apply. This warranty gives you specific legal rights and you may also have other rights which vary from state to state.

For Warranty Claims: Send complete tool with all your information and details of the problem to an Authorized Warranty Repair Center, transportation prepaid. Do not send tool accessories.

PRODUCT REGISTRATION CARD

Model No. PSG-125 Serial No. _____

Company Name: _____

Name: _____

Address: _____

City: _____ State: _____ Zip: _____

Email: _____

Telephone: _____

Purchase Date: _____

Dealer's Name: _____

Note: Serial & Model Number must be included for proper registration.



Alpha Professional Tools®

(800) 648-7229



Register online at:
www.alpha-tools.com/productregistration.aspx

Mail or Fax to:
Alpha Professional Tools®
103 Bauer Drive, Oakland, NJ 07436
Fax: 800-286-0114

Photocopy of product registration form will be accepted.



103 Bauer Drive, Oakland, NJ 07436 • 800-648-7229 • Fax: 800-286-0114
www.alpha-tools.com

Copyright © 2016 Alpha Professional Tools. All rights reserved.

11/2016