

# Alpha<sup>®</sup> Pneumatic 5" Gear Action Sander/Polisher



**Part No: GDSP-05**  
Version 1



**Safety Warning:** Always wear eye and respiratory protection as well as proper personal safety equipment when using this product. Comply with ANSI B7.1 and OSHA requirements.

 **Alpha Professional Tools**<sup>®</sup>

103 Bauer Drive, Oakland, NJ 07436 • 800-648-7229 • Fax: 800-286-0114  
[www.alpha-tools.com](http://www.alpha-tools.com)

# 5" Gear Action Sander/Polisher

Part No.: GDSP-05

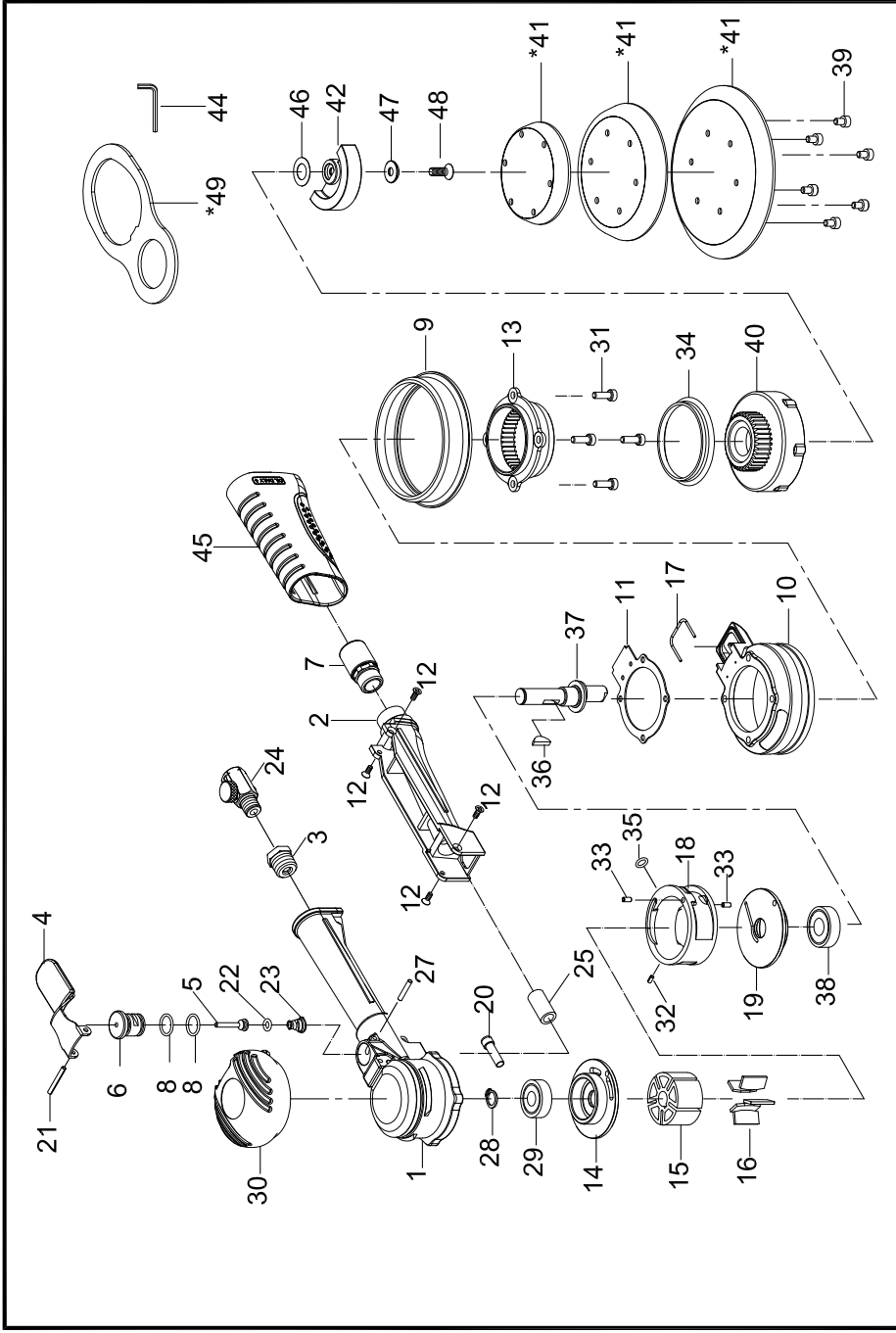

Index No.	Parts No.	Description	Index No.	Parts No.	Description
1	66-613201	Housing	27	PN03001708	Pin (3×17.8L)
2	66-613202	Adapter	28	66-6132A12	Retainer Ring
3	30103	Air Inlet	29	051220	Ball Bearing (6000zz)
4	66-6132A04	Throttle Lever	30	66-6132A30	Rubber Hat
5	66-6132A05	Valve	31	60-613143	Screw(4) (M4×14)
6	66-613206	Bushing	32	70117-13	Spring Pin (2.5×5L)
7	66-613224-11S	Silencer	33	63062	Spring Pin(2) (3×6L)
8	OR01200105-V	O-Ring(2) (12×1.5)	34	G5-513255	Shroud
9	G5-513254	Shroud	35	40333-V	O-Ring (6×1.5)
10	G5-513229	Plastic Shroud	36	61934	Key (3×13)
11	G5-513211	Gasket	37	G5-513237	Balancer Shaft
12	61035	Screw(4) (M3x8)	38	060313	Ball Bearing (6001zz)
13	G5-513207	Internal Gear	39	65-613830	Screw(6) (M4X6)
14	G5-513214	Rear End Plate	40	G5-513202	Drive Seat
15	66-6132A15	Rotor		G3-513242	Pad (3")
16	66-5137C16	Rotor Blade(5)	*41	G4-513242	Pad (4")
17	66-6132A17	Rubber Strip		G5-513242	Pad (5")
18	G5-513218	Cylinder		G3-513236	Balancer (for G3 & G4)
19	G5-513219	Front End Plate	42	G5-513236	Balancer (for G5)
20	66-613220	Brass Tube	44	10012	HEX. Wrench (3mm)
21	30102	Spring Pin (3×24)	45	66-6132A52	Grip
22	70107-V	O-Ring (P5)	46	G5-513238	Washer
23	51208	Spring	47	G5-513227	Washer
24	61558-21	Regulator	48	G5-513250	Screw (M5×14)
25	66-613207	Rubber Tube	*49	G5-513257	Hook

\*Optional parts

G3-5132-0001  
G4-5132-0001  
G5-5132-0001

# **Alpha® Pneumatic 5" Gear Action Sander/Polisher** Part No.: GDSP-05

---

## ▶ FEATURES:

- One or Two-Handed Operation
- Low Speed High Torque
- Random Orbital **Fine Polishing and Sanding**
- Lightweight
- Low Noise

## ▶ SPECIFICATIONS:

- **Free Speed:** 1,300 RPM
- **Pad Size:** 5" (125mm)
- **Orbit Diameter:** 3/16" (5mm)
- **Air Inlet:** 1/4" NPT
- **Hose Size ID:** 3/8" (10mm)
- **Air Consumption:** 3 CFM (85L/min)
- **Length:** 10" (254mm)
- **Weight:** 2.2 lbs (1.0kg)
- **Noise Level:** 84dB(A)
- **Recommended Air Pressure:** 90 PSI (6.2 Bars)

